

DEPARTMENT OF THE ARMY SUPPLY BULLETIN

Storage Serviceability Standard for USAECOM Materiel

RADIO SET AN/ARC-54

Headquarters, Department of the Army, Washington, D.C.
6 July 1972

	Paragraph	Page
SECTION I. INTRODUCTION		
Purpose	1	1
Scope	2	1
General	3	1
Definitions	4	2
Reporting of supply bulletin improvements	5	2
II. STORAGE AND SPECIAL INSTRUCTIONS		
Preservation, packaging, and packing	6	2
Marking	7	2
Storage	8	2
Disposition of rejected materiel	9	2
APPENDIX A. REFERENCES		3
B. FEDERAL STOCK NUMBERS AND TEST REQUIREMENTS		4
C. PRESERVATION, PACKAGING, AND PACKING		6
D. STORAGE, QUALITY ASSURANCE PROVISIONS		7

SECTION I INTRODUCTION

1. Purpose. This bulletin provides a storage serviceability standard which establishes uniform criteria for determining the acceptability of the items designated herein, for continued storage and/or issue on the condition that all specifications and requirements applicable to the items have been met previously at the time of receipt from new procurement or after repair, overhaul, or rebuild by a CONUS depot maintenance shop.

2. Scope. This bulletin applies to all activities engaged in the receipt, storage, and issue of USAECOM Radio Set AN/ARC-54 hereinafter referred to as the radio set, listed in appendix B with the federal stock number (FSN).

3. General. It is the Army's objective to attain

and maintain a constant materiel readiness status for materiel in depot stocks. The scope of such an objective is of such magnitude that only general guidelines are provided by section VIII, chapter 3, of TM 743-200 for the quality evaluation of material in the custody of supply and storage activities. This standard supplements TM743-200-1 by providing a systematic procedure for storage cyclic inspection of the materiel and indicates the limiting degree of deterioration, damage, unsatisfactory storage practices, and other characteristics which are acceptable. It also establishes the basis for identifying materiel requiring segregation, remedial care and preservation, or reclassification action. Applicable requirements of the standard maybe used for performing receipt and preshipment quality control inspections.

4. Definitions. Definitions for the majority of specialized terms used herein can be found in MIL-STD-109. Definitions for other specialized terms areas follows:

a. Storage serviceability standard. A written procedure providing storage methods and standards and prescribing the necessary requirements for the surveillance of materiel in storage.

b. Storage quality level (SQL). That quality level applicable to storage sampling inspection expressed in terms of percent defective or defects per hundred units, whichever is applicable, specified for a given group of defects of a product.

It is the maximum allowable accidental departure from specification requirements which can be tolerated.

5. Reporting of Supply Bulletin Improvements.

The reporting of errors, omissions, and recommendations for improving this publication by the individual user is encouraged. Reports shall be submitted on DA Form 2028 (Recommended Changes to Publications) and forwarded direct to U.S. Army Electronics Command ATTN: AMSEL-MA-AC, Ft. Monmouth, N.J. 07703.

SECTION II

STORAGE AND SPECIAL INSTRUCTIONS

6. Preservation, Packaging, and Packing. Preservation, packaging, and packing of the radio set shall be in accordance with the requirements listed in appendix C. All items shall be preserved and packaged in accordance with MIL-STD-726C; packing shall conform to the requirements specified in MIL-P-55585 (EL).

7. Marking. In addition to any special marking required by the contract or order, interior packages and exterior shipping containers shall be marked in accordance with MIL-STD-129D.

8. Storage. *a. Type.* The preferred type of storage environment for the radio set is a controlled humidity warehouse or heated warehouse.

b. Age Control. The radio set will be issued on a first-in-first-out (FIFO) basis by date of manufacture, or date of rebuild. The dates can be established from the original government procurement contract number or the rebuild lot number.

c. Shelf Life. The radio set is subject to deterioration during storage and is required to be inspected and tested as specified in appendix D.

d. Tests. All test requirements for the radio set with the federal stock numbers of each unit are given in appendix B.

e. Precautionary Action. When the radio set is being prepared for storage or issue, be sure that there are enough personnel and sufficient moving apparatus available to eliminate the possibility of damage to the equipment or injury to the personnel.

9. Disposition of Rejected Materiel. Rejected materiel will be tagged and reclassified into the proper condition code in accordance with AR 725-50. For other than new materiel all defective units in a lot shall be repaired, or disposition requested in accordance with AMC and depot procedures.

APPENDIX A

REFERENCES

MIL-P-55585 (EL)	Packing and Marking Requirements for Southeast Asia and Stratcom and Preparation for Delivery Requirements of Electronics Equipment and Components.
MIL-STD-109B	Quality Assurance Terms and Definitions.
MIL-STD-129D	Marking for Shipment and Storage.
MIL-STD-726C	Packaging Requirements Code.
TM 743-200-1	Storage and Materials Handling.

APPENDIX B

FEDERAL STOCK NUMBERS AND TEST REQUIREMENTS

Type	FSN	Publication	Test Requirements
Receiver-Transmitter Radio RT-348/ ARC-54	5821-082-3597	TM 11-5821-244-35	Paragraphs 5-5 through 5-17, 1 and 5-24
		TM 11-5821-244-12	Paragraph 27 as applicable
Control Radio Set C-3835/ARC-54	5821-082-3599	TM 11-5821-244-35	Paragraphs 5-18 through 5-21, and 5-25
		TM 11-5821-244-12	Paragraph 27 as applicable
Mounting MT-1535/ARC-54	5821-892-9309	TM 11-5821-244-35	All tests with the Receiver-Transmitter
		TM 11-5821-244-12	Paragraph 27 as applicable

APPENDIX C

PRESERVATION, PACKAGING, AND PACKING

1. Preservation and Packaging. Preservation and packaging shall be level A, or C as specified.

a. Level A.

(1) *Cleaning.* Each radio set and units shall be cleaned in accordance with the applicable procedure of MIL-P-116.

(2) *Drying.* Each radio set and units shall be dried in accordance with the applicable procedure of MIL-P-116.

(3) *Preservation application.* None required.

(4) *Unit packaging.* Unit packaging shall be in accordance with the methods prescribed in MIL-P-116 as specified herein.

(a) *Technical literature.* Technical literature shall be packaged method IC-1.

(b) *Control, Radio Set C-3835 ()/ARC-5.4.* Each control shall be individually packaged method 111 as follows: Wrap the control with a minimum of two full layers of cushioning material conforming to PPP-C-843, type II, Class B, designed to protect all projections and to absorb the shock of impact in handling and transit. Place the cushioned item within a close-fitting, fiberboard box conforming to PPP-B-636, W5c. Close the box in accordance with the appendix of the box specification.

(c) *Receiver-Transmitter Radio RT-348 ()/ARC-5-4 or Mounting MT-1535 ()/ARC-54.* Each receiver-transmitter or mounting shall be individually packaged method 111 as follows: Cushion the unit on all surfaces with cells or pads or both fabricated of fiberboard conforming to PPP-F-320, type CF, class weather-resistant, variety SW, grade W5c, designed to protect all projections and absorb the shock of impact in handling and transit. Place the cushioned unit within a close-fitting fiberboard box conforming to PPP-B-636, W5c. Close the box in accordance with the appendix of the box specification.

(d) *Radio Set AN/ARC-54 ().* Each radio set shall be individually packaged method 111 as follows: Install the receiver-transmitter on the mounting and secure the locking handle on

the receiver-transmitter to the holddown bars of the mounting. Individually cushion the receiver-transmitter installed on the mounting and the radio set control on all surfaces with cells or pads or both fabricated of fiberboard conforming to PPP-F-320, type CF, class weather-resistant, variety SW, grade W5c, designed to protect all projections and to absorb the shock of impact in handling and transit. Place the cushioned items within a close-fitting fiberboard box conforming to the cushioning material or dummy boxes conforming to the container material to prevent movement of the contents during handling and transit. Place the technical literature, packaged as specified in (a) above, on top of the contents, directly under the lid of the box. Close the box in accordance with the appendix of the box specification.

b. Level C. The radio sets shall be packaged in a manner that will afford adequate protection against physical and environmental damage during shipment, handling, and limited intransit storage.

2. Packing. Packing shall be level A, B, or C as specified. Shipping containers for all levels shall be capable of stacking and supporting superimposed loads during shipment and storage without damaging the container (s) or its contents.

a. Level A.

(1) *Palletized load.* A quantity of radio sets packaged as specified in 1 above, shall be placed on a pallet, load type 1, conforming to MIL-STD-147 except that the pallet shall be softwood conforming to NN-P-71, type IV, size 2. A fiberboard cap shall be employed over the load having two sides extending down the stacked load at least 12 inches to accommodate marking requirements. The cap shall be fabricated of fiberboard conforming to PPP-F-320, class weather-resistant, W5s or V3c. The load shall be "bonded" to the pallet by strapping.

(2) *Less than palletized load.* When quanti-

ties per destination are less than a pallet load, the item packaged as specified in 1 above, shall be waterproofed, with tape conforming to PPP-T-76, in accordance with the taping requirements of the box specification. A quantity of the waterproofed containers shall be packed within a close-fitting box conforming to PPP-B-601, overseas type; PPP-B-621, style 4, class 2; or PPP-B-585, style 2 or 3, class 3. When the gross weight exceeds 200 pounds, or the container length and width is 48 x 24 inches or more and the weight exceeds 100 pounds, 3 x 4 inch skids, laid flat, shall be applied in accordance with the requirements of the container specification, or if not specified in the specification, in a manner which will adequately support the item and facilitate the use of material handling equipment. Closure and strapping shall be in accordance with the applicable container specification or appendix thereto except that metal strapping shall conform to QQ-S-781, type 1, class B.

b. Level B.

(1) *Palletized load.* A quantity of radio sets, packaged as specified in 1 above, shall be palletized as specified in *a.* (1) above.

(2) *Less than palletized load.* When quantities per destination are less than a pallet load, a quantity of radio sets, packaged as specified in 1 above, shall be packed within a close-fitting fiberboard box conforming to PPP-B-640, class 2,

style E, or PPP-B-636, type CF, class weather-resistant, variety DW. The gross weight of boxes conforming to PPP-B-640 shall not exceed 250 pounds. When the gross weight exceeds 200 pounds, or the container length and width is 48 x 24 inches or more and the weight exceeds 100 pounds, containers will be pallet-mounted on pallets conforming to NN-P-71, type IV. Closure shall be in accordance with the appendix of the applicable box specification, Reinforcing shall be pressure-sensitive filament tape banding or non-metallic strapping conforming to PPP-T-97, type IV and PPP-S-760, respectively; selection of the material and application shall be in accordance with the appendix of the applicable box specification.

c. Level C.

(1) *Palletized load.* A quantity of radio sets, packaged as specified in 1 above, shall be palletized as specified in *a.* (1) above, except that the fiberboard caps shall be class domestic.

(2) *Less than palletized load.* When quantities per destination are less than a pallet load, a quantity of radio sets, packaged as specified in 1 above, shall be packed as specified in *b.* (2) above, except that the fiberboard boxes shall conform to PPP-B-640 and PPP-B-636, class 1 and class domestic, respectively, and reinforcing shall not be required for boxes conforming to PPP-B-636.

APPENDIX D

STORAGE QUALITY ASSURANCE PROVISIONS

1. Index Number. The four-digit index number of this storage quality assurance provision (SQAP) (reserved for future use in automatic data processing) will be assigned when available.

2. Federal Stock Number. Each item listed in appendix B, with its federal stock number, is subject to the provisions of this SQAP.

3. Definitions. Special terms used in this SQAP are defined as follows:

a. Acceptance Quality Level (AQL). The nominal value expressed in terms of percent defective or defects per 100 units, whichever is applicable, specified for a given group of defects of a product. It is the maximum allowable accidental departure from specification requirements which can be tolerated.

b. Storage Quality Level (SQL). That quality level applicable to storage sampling inspection expressed in terms of percent defective or defects per 100 units, whichever is applicable, specified for a given group of defects of a product. It is the maximum allowable accidental departure from specification requirements which can be tolerated.

c. Defect. Any nonconformance of the unit of product with specified requirements.

d. Defective Unit. A unit of product which contains one or more defects.

e. Critical Defect. A defect that judgement and experience indicate is likely to result in hazardous or unsafe conditions for individuals using, maintaining, or depending on the product performance of the tactical function of a major end item, such as a ship, aircraft, tank, missile, or space vehicle.

f. Major Defect. A defect other than critical that could result in failure, or materially reduce the usability of the product for its intended purpose.

g. Minor Defect. A defect that does not materially reduce the usability of the unit of product for its intended purpose, or is a departure from

established standards having little bearing on the effective use or operation of the unit.

h. Mechanical-Visual Inspection. An inspection by visual means to observe the item and/or packaging and packing to detect deficiencies. Mechanical-visual inspection may require disassembly.

i. Technical Inspection. A complete functional inspection, including disassembly, where required, and performance testing and/or laboratory testing.

4. Specifications, Technical Manuals, and Other Documents. The following documents of the latest issue in effect, contain inspection and testing information, data, and instructions applicable to these quality assurance provisions.

<i>Publication</i>	<i>Title</i>
DA Pam 310-4	Index of Technical Manuals, Technical Bulletins, Supply Manuals (types 7, 8, and 9), Supply Bulletins, and Lubrication Orders.
DA Pam 310-7	U.S. Army Equipment Index of Modification Work Orders.
AR-725-50	Requisitioning, Receipt, and Issue System.
MIL-P-116	Preservation, Methods
MIL-P-11268	Parts, Materials and Processes Used in Electronic Communication Equipment.
MIL-NI-13231	Marking of Electronic Items.
MIL-STD-105D	Sampling Procedures and Tables for Inspection by Attributes.
MIL-STD-109B	Quality Assurance Terms and Definitions,
MIL-STD-129D	Marking for Shipment and Storage.
MIL-STD-130C	Identification Marking of U.S. Military Property.
MIL-STD-252A	Wired Equipment, Classification of Visual and Mechanical Defects.
MIL-STD-726C	Packaging Requirements Code.
SCL-T-0019E	Testing of Radio Set/ARC-54 () For Army Aircraft, Bench, Preflight and Flight Tests.
TB SIG 355-1	Depot Inspection Standard for Repaired Signal Equipment.
TB SIG 355-2	Depot Inspection Standard for

<i>Publication</i>	<i>Title</i>
	Refinishing Repaired Signal Equipment.
TB SIG 355-3	Depot Inspection Standard for Moisture and Fungus Resistant Treatment.
TB SIG 355-4	Depot Inspection Standard for Balancing Rotating Parts and Assemblies.
TB 750-236	Calibration Requirements for the Maintenance of Army Material.
TM 38-750	The Army Maintenance Management System (TAMMS).
TM 11-5821-244-12	Operator and Organizational Maintenance Manual Radio Set AN/ARC-54.
TM 11-5821-244-20P	Organizational Maintenance Repair Parts and Special Tool List Radio Set AN/ARC-54.
TM 11-5821-244-35	DS, GS, and Depot Maintenance Manual Radio Set AN/ARC-54.
TM 11-5821-244-35P	DS, GS and Depot Maintenance Repair Parts and Special Tool Lists Radio Set AN/ARC-54.

5. Other Directives.

AR 795-17	General Policies and Principles for Furnishing Army Material on a Grant Aid Basis.
AR 795-204	General Policies and Principles for Furnishing Defense Articles and Services on a Sale or Loan Basis.

6. Inspection Criteria. *a. Lot Criteria.*

(1) *Lot definition.* A lot is defined as a group of like items from which a sample is to be drawn and inspected to determine conformance with the acceptability criteria. The following are examples:

(a) A group of like items in storage which was received in a shipment with the following identical markings:

1. Purchase order number.
2. Data packaged or packed.
3. Depot certification stamp and date.

(b) A group of like items repaired or rebuilt by the Maintenance Division in one production run.

(2) *Lot formation.* The items shall be assembled into identifiable lots. Each lot shall, as far as practicable, consist of units of product of a single type, grade, class, size, and composition manufactured, repaired, or rebuilt at the same time and stored under the same conditions. It is recommended that equipment from different limited production buys be placed in different lots and that the equipment serial numbers, by limited production buy, be used as lot information criteria.

(3) *Lot size.* The lot size is the total number

of individual like items in the lot that is to be inspected.

b. Sampling Procedure.

(1) *Sample selection.* Select samples of material in a way which will assure that each unit in the lot has an equal chance of being selected. Biased methods, such as selecting items from the same position in a container, pallet, or stacks; taking items all from one location; or selecting items that appear defective, will not be utilized.

(2) *Sample size.* Use table I, MIL-STD-105D, General Inspection Level II, to obtain sample size code letter and table II-A, MIL-STD-105D to obtain the sample size utilizing the storage quality level shown in (3) below.

(3) *Storage quality levels (SQL).*

(a) Mechanical-visual inspection: Critical SQL 1.0 percent; major SQL 2.5 percent; minor SQL 10 percent.

(b) Electrical: Critical SQL 1.0 percent; major SQL 2.5 percent.

(c) Preservation, packaging, packing, and marking: major SQL 4.0 percent; minor SQL 10 percent.

(d) The acceptance or reject number for the above SQL's shall be the same as those shown for comparable acceptance quality levels (AQL's) in table II-A of MIL-STD-105D.

c. Inspection Requirements. The following mechanical-visual inspections shall be performed.

(1) Inspect equipment covers and front panels for condition of finish and panel markings.

(2) Inspect for dents, punctures, or warped areas.

(3) Inspect springlock fasteners and receptacles.

(4) Inspect external surfaces for loose or missing screws or washers.

(5) Inspect receptacles for condition of pins, contacts, and mounting, and foreign particles.

(6) Inspect air filters and air outlet.

(7) Operate all controls through all their positions (do not disturb screwdriver adjustments). Controls shall operate smoothly with no binding. Control knobs shall be tight on their shafts with no missing or loose hardware.

(8) Operate receiver-transmitter unit locking handles. The locking handle shall operate smoothly and the locking handle catch shall secure the handle properly.

(9) Inspect the meter; it shall be clean and free of damage.

(10) Inspect solder connections for missing solder, cold solder, insufficient solder, excessive solder, and improper wrap.

(11) Inspect for illegible, incorrect, or missing markings.

(12) Inspect for corrosion, dirt, moisture, and fungus.

(13) Inspect all hardware and parts for damage and condition.

(14) Inspect the equipment for applicable modification work orders. A listing of current modification work orders will be found in DA Pam 310-7.

d. Bench Test Requirements. Bench tests are required to assure that the equipment operates satisfactorily and has not been damaged in shipping and handling. Radio Sets AN/ARC-54 () in storage for a period of time are subject to deterioration and bench tests shall be conducted on all items prior to shipment, and at required intervals. The bench tests shall be conducted in a screen or RF shield room with the equipment under test arranged so the component parts and adjustments are readily accessible. The power source shall include suitable filtering and overload protection.

NOTE

Equivalent test equipment may be substituted.

Table D-1. Test Equipment and Accessories

Equipment	Qty Reqd	Applicable Literature
RF Wattmeter AN/URM-120	1	TM 11-6625-446-15
Audio Oscillator TS-382 A/U	1	TM 11-6625-261-12
Frequency meter AN/USM-26	1	TM 11-6625-212-15
Modulation meter ME-57/U	1	TM 11-6625-400-12
Vacuum Tube Voltmeter TS 505/U	1	TM 11-6625-239-12
Signal Generator AN/URM-48	1	TM 11-1257
Attenuator fixed (50 ohms 20 db)	1	
Indicator ID-1351/A	1	TM 11-5895-537-50
Indicator ID-48/ARN	1	TM 11-5840-270-50
Deviation Meter ARF AR-1B	1	
Frequency Converter CV-394/USA-5	1	TM 11-6625-604-15
Mounting MT-1535 ()/ARC-54	1	
Attenuator, 50 ohms, stepped in 1 db steps	2	
Radio Set Control C-3835/ARC-54	1	
Test Harness	1	

Equipment	Qty Reqd	Applicable Literature
Resistor, 150 ohms \pm 5%, 1/2 watt	1	
Resistor, 470 ohms \pm 5%, 1/2 watt	1	
Capacitor, 0.2 ufd, 400 vdc	1	

(1) *Standard conditions.* Standard conditions hereafter referred to, will be as follows or as otherwise specified:

(a) Power supply voltage: 27.5 \pm 0.5 volts dc.

(b) Radio set turned to ON, the OFF-PTT-RETRAN-HOME control set to PTT.

(c) Warmup time: One minute.

(d) Operational duty cycle: 1 minute transmit, 10 minute receive.

(e) Output impedance: RF-52 ohms, audio 150 ohms.

(f) Output level: RF 10 watts, audio 50 milliwatts, (2.73 Vrms across 150 ohms.)

(g) Input impedance: RF 52 ohms, audio 150 ohms.

(h) Transmitter input level: audio 0 dbm at 1000 Hz (0.37 Vrms across 150 ohms).

(2) *Input requirements. (Electrical power).* Radio set AN/ARC-54 operates from a 27.5 volt dc power source having characteristics as defined in MIL-STD-704. A maximum of 7.4 amperes at 27.5 volts dc is required under transmit conditions.

(3) *Test procedures.* Receiver-transmitter RT-348()/ARC-54 shall be installed in mounting MT-1535()/ARC-54 when conducting the following tests. Suitable access holes shall be provided in the underside of the mounting and bottom plate used to allow adjustments to the transmit and receive audio modules specified herein.

CAUTION

Damage may occur to the receiver-transmitter unit when inserted into the mounting with the dust cover removed. The damage can be prevented by elevating the back of the receiver-transmitter unit during installation to insure proper alignment of the connectors.

(4) *Transmitter tests.* Refer to figure 1. Connect the RF wattmeter AN/URM-120 to the antenna receptacle on the rear of the receiver-transmitter with a convenient length of cable RG-58/U or RG-223/U.

CAUTIONS

1. Do not transmit with the signal generator and pad connected to the

receiver-transmitter. Serious damage to the pad and signal generator may result.

2. Do not perform any tests until the receiver-transmitter has been allowed to warm up for at least one minute.

3. Transmission should not be attempted during the channel changing cycle.

(a) *Transmitter power output.* Under standard conditions of (1) above and with the test set up as shown in figure 1, check the transmitter for a minimum of 10 watts output at the following frequencies in sequences specified. The maximum error for each frequency shall not be greater than ± 0.01 percent. Allocated frequencies shall be made part of this unit.

Frequency (MHz)	Frequency (MHz)
1. 30.00	7. 50.55
2. 34.10	8. 55.65
3. 37.20	9. 59.75
4. 38.00	10. 63.85
5. 40.30	11. 67.95
6. 44.45	12. 69.95

NOTE

The RF cabling arrangement shown in figure 1 shall be replaced with a single RG-58/U or RG-223/U cable between the receiver-transmitter unit and the AN/URM-120 for this test. The input voltage shall be at least 27.5 vdc at the transmitter fuse for this test.

(b) *Frequency deviation and sidetone test.* Under standard conditions of (1) above and with the test setup as shown in figure 1, set the transmitter to operate at 30.00 MHz. Adjust the audio oscillator TS-382A/U for a signal level of 0.37 Vrms at 1000 Hz between pins Y and KK (ground) of J-101. The frequency deviation shall be 10 kHz. (If the deviation is not within these limits, adjust "AUDIO" control R-1402 on the transmit audio module, for a deviation of 10 kHz.) The sidetone output level shall be 1.09 Vrms as measured with the VTVM across the volume control when adjusted for a maximum volume. (Adjust "SIDETONE" control R-1413, as necessary to achieve the specified output.) Remove the audio input and key the transmitter. The deviation shall be $3000 \text{ Hz} \pm 500 \text{ Hz}$. Connect a 0.2 mf capacitor across the modulation meter ME-57/U AUDIO OUTPUT terminals and check the tone frequency as indicated on the frequency meter AN/USM-26. The tone frequency shall be $150 \text{ Hz} \pm 3 \text{ Hz}$.

NOTE

Due to an interaction between the "SIDETONE" control R-1413 and the "AUDIO" control R-1402, the test re-

suits shall be considered acceptable when the performance is within the limits specified without further adjustment of the respective controls.

(c) *Channel changing tone.* A tone of approximately 800 Hz shall be present at the receiver audio output during the complete channel changing cycle. The tone shall be of sufficient magnitude to be clearly audible after installation of the AN/ARC-54 subsystem in the designated aircraft.

(d) *"X" mode deviation test.* Under standard conditions of (1) above and with the test set up as in figure 2, perform the following tests:

1. Adjust the audio oscillator for zero signal output, Set the transmitter frequency to 30 MHz. Key the transmitter and measure the deviation. The deviation shall be $3 \text{ kHz} \pm 0.5 \text{ kHz}$.

2. Connect pin no. 39 of P1005 to ground (pin no. 38); the deviation shall be zero.

3. With pin no. 39 connected to ground, adjust the audio oscillator for a signal input level of $8.2 \pm 0.5 \text{ Vrms}$ at 1000 Hz between pins no. 7 and no. 38 (ground) of P-1005. The deviation shall be $9.5 \pm 2.5 \text{ kHz}$.

(5) Receiver tests.

(a) *Audio output test:* Under standard conditions of (1) above and with the test set up as shown in figure 3, perform the following test. Using a 30 MHz signal modulated $\pm 10 \text{ kHz}$ set the signal generator AN/URM-48 output level to provide 100 microvolt input to the receiver-transmitter antenna, (terminal P-1002). The audio output shall be not less than 41.6 milliwatts (2.50 Vrms across the volume control when adjusted for maximum volume.) If necessary, adjust "GAIN" control R-1315 of the receiver audio module to obtain the specified output.

(b) *Sensitivity tests.* Under standard conditions of (1) above and with the test set up as shown in figure 3, set the C-3835()/ARC-54 controls for receive operation OFF-PTT-RETRAN-HOME switch to PTT and the SQUELCH switch to DIS and the volume control fully clockwise. Set the signal generator output level as indicated in figure 3, deviated $\pm 10 \text{ kHz}$ at 1000 Hz and measure the signal plus noise-to-noise ratio. The ratio shall be 10 db or greater. Conduct this test at the following frequencies:

MHz	MHz	MHz	MHz	MHz
30.00	38.25	48.50	60.80	69.95
33.05	42.35	52.60	64.90	
36.15	47.40	56.70	67.05	

(c) *Squelch sensitivity.* Under standard conditions of (1) above and with the test set up

as shown in figure 3, perform the following test. Using a 30 MHz signal modulated ± 10 kHz at 1000 Hz set the signal generator output level for zero output. Adjust the "SQ-ADJ" control for minimum sensitivity (fully clockwise) and slowly increase the signal generator output level until the receiver is unscelched. The receiver shall unscelch between 1.0 uv and 6.0 uv. Set the signal generator output level for zero output. Adjust the "SQ-ADJ" control for maximum sensitivity (fully counterclockwise). Under this condition, the receiver shall be unscelched as indicated by the presence of background noise, at the audio output terminals. The receiver shall be considered scelched when the audio output is 30 db (0.078 volts) below the 41.6 milliwatt (250 Vrms) level across the volume control when adjusted for full volume. Readjust the scelch potentiometer on the receiver-transmitter front panel for a 1 microvolt reading on the signal generator.

(d) *Tone scelch test.* (This test shall be conducted only when the "TONE" mode of operation is specified.) Under standard conditions of (1) above and with the test set up as shown in figure 4, perform the following tests:

1. Set the signal generator OPERATION switch to EXT MOD, and RF ATTENUATOR MICROVOLTS to minimum.

2. Set the audio oscillator output level control for reading on the signal generator DEVIATION meter of 3 kHz.

3. Slowly increase setting of the signal generator RF ATTENUATOR MICROVOLTS (maintain redline adjustment of RF SET TO LINE adjust) until the receiver is unscelched, at an input of 1.2 microvolt or less.

4. Set the signal generator RF ATTENUATOR MICROVOLTS to 120, adjust for 2.5 kHz deviation, and set the audio oscillator main tuning dial to 145 Hz. Set the signal generator OPERATION switch to MOD OFF and note that receiver scelches as indicated by a sharp decrease in reading on the VTVM. Set the signal generator OPERATION switch to EXT MOD and verify that the receiver unscelches. The receiver shall scelch with the modulation off and unscelch with the modulation on.

5. Set the audio oscillator main tuning dial to 155 Hz (maintain 2.5 kHz deviation and note the same results as in 4 above).

(e) *Homing test.* (These tests are to be performed with the signal generator modulation "OFF"). Under standard conditions of (1) above and using the test set up as in figure 5, perform the following tests:

1. Set the C-3835/ARC-54 to 50 MHz and the function selector to HOME, the scelch switch to CARR. Adjust the signal generator for zero output at 50 MHz. Set the two adjustable attenuators to 6 db. Increase the signal generator output until a "flag down" condition is observed on the Indicator ID-48. The signal level required for "flag down" condition shall not exceed 4.8 microvolt.

2. Set the signal generator attenuator to 50 MHz and the RF ATTENUATOR to 120 microvolt and unbalance the adjustable pads by 1.0 db. Fine tune the signal generator for a maximum deflection of the vertical needle. Re-balance the attenuators to 6.0 db each. The needle shall be centered or within 1.2 dot width either side of center or plus or minus 10 microamps. If not, adjust R-227 on the homer needle to center the needle. The limits for homing zero inclination shall be 0.0 plus or minus 10 microamps. This requirement shall also be met at one frequency in each of the following ranges: 30.00 MHz to 33.95 MHz and 67.00 MHz to 69.95 MHz. Any readjustment of R-227 at other than 50 MHz shall be rechecked at 50 MHz for a compromise reading.

3. With an input of 120 microvolt from the signal generator set the left pad at 3 db and the right pad at 6 db, the course indicator shall deflect to the left. Set the left pad at 6 db and the right pad at 3 db, the course indicator shall deflect to the right. The vertical needle deflection shall be between the first and second dots on the horizontal scale of the ID-48 indicator or 138 microampere ± 10 percent. If necessary, adjust R-224 to obtain the desired deflection.

4. Set the two adjustable attenuators to 6 db and verify that the needle is centered within $\frac{1}{2}$ dot, if the needle is not within $\frac{1}{2}$ dot adjust R-227 for center.

5. Set one adjustable attenuator to 3 db and the other attenuator to 6 db. Under this condition and for all values a signal input level of 12 microvolt to 10,000 microvolt from the signal generator, the vertical needle shall deflect at least to the wing tip of the ID-48 indicator or at least 90 microampere on the horizontal scale, Change the attenuator settings from 3 db to 6 db and 6 db to 3 db respectively. The vertical needle deflection shall be in the opposite direction. This requirement shall also be met at one frequency in each of the following ranges: 30.00 MHz to 33.95 MHz and 67.00 MHz to 69.95 MHz.

NOTE

When Indicator ID-1351A is used and correct response to left and right indica-

tions is not obtained after adjustments of R-224 and R-227, it may be necessary to adjust coils L-204 and L-205. The coils should be peaked at 50.00 MHz. A frequency counter such as the CP-772/U with plug-in unit CV-2002/U or equivalent should be used to make sure that the signal generator is on FREQUENCY. When these coils are peaked, resistors R-224 and R-227 may have to be re-adjusted. If the RF and IF sections of the AN/ARC-54() are properly

aligned, proper left-right deflection will now be possible.

6. With each adjustable attenuator set for 6 db each, set the signal generator output to 2000 microvolt. When using the ID-1351A, the horizontal pointer (signal strength indicator) on the left side of the ID-135/A should be centered on the first dot below the rest position of the pointer. If a microamp meter is used, the reading shall be 37.5 microamps plus or minus 20 microamps. If the above indication or microamp reading cannot be obtained, adjust R-211 on the

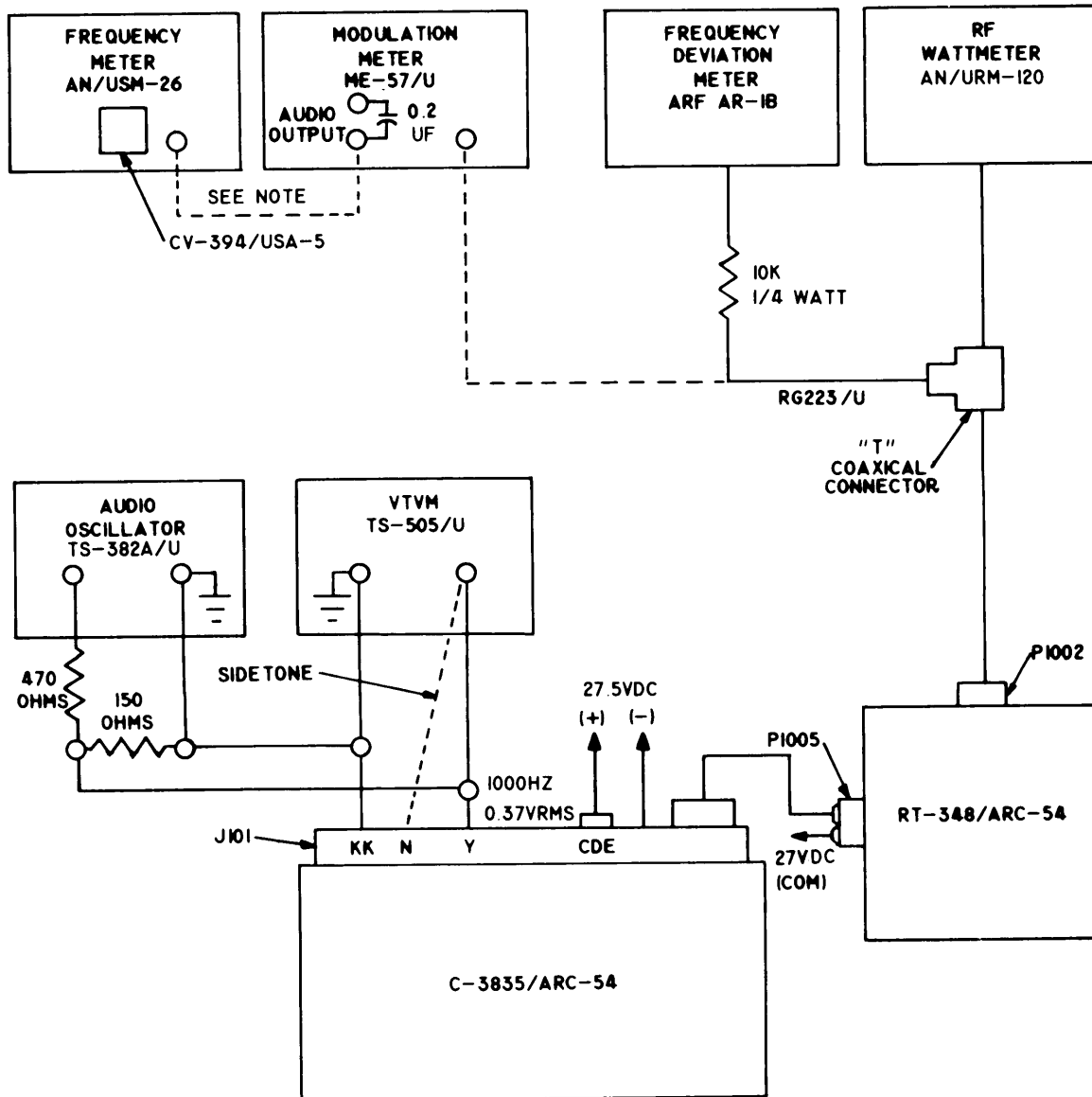

NOTE:
 CONNECTION OF MODULATION METER,
 FREQUENCY METER AND 0.2UF CAPACITOR
 IS FOR TONE DEVIATION TEST

EL740-5821-91-004-SB-1

Figure 1. Transmitter test set up.

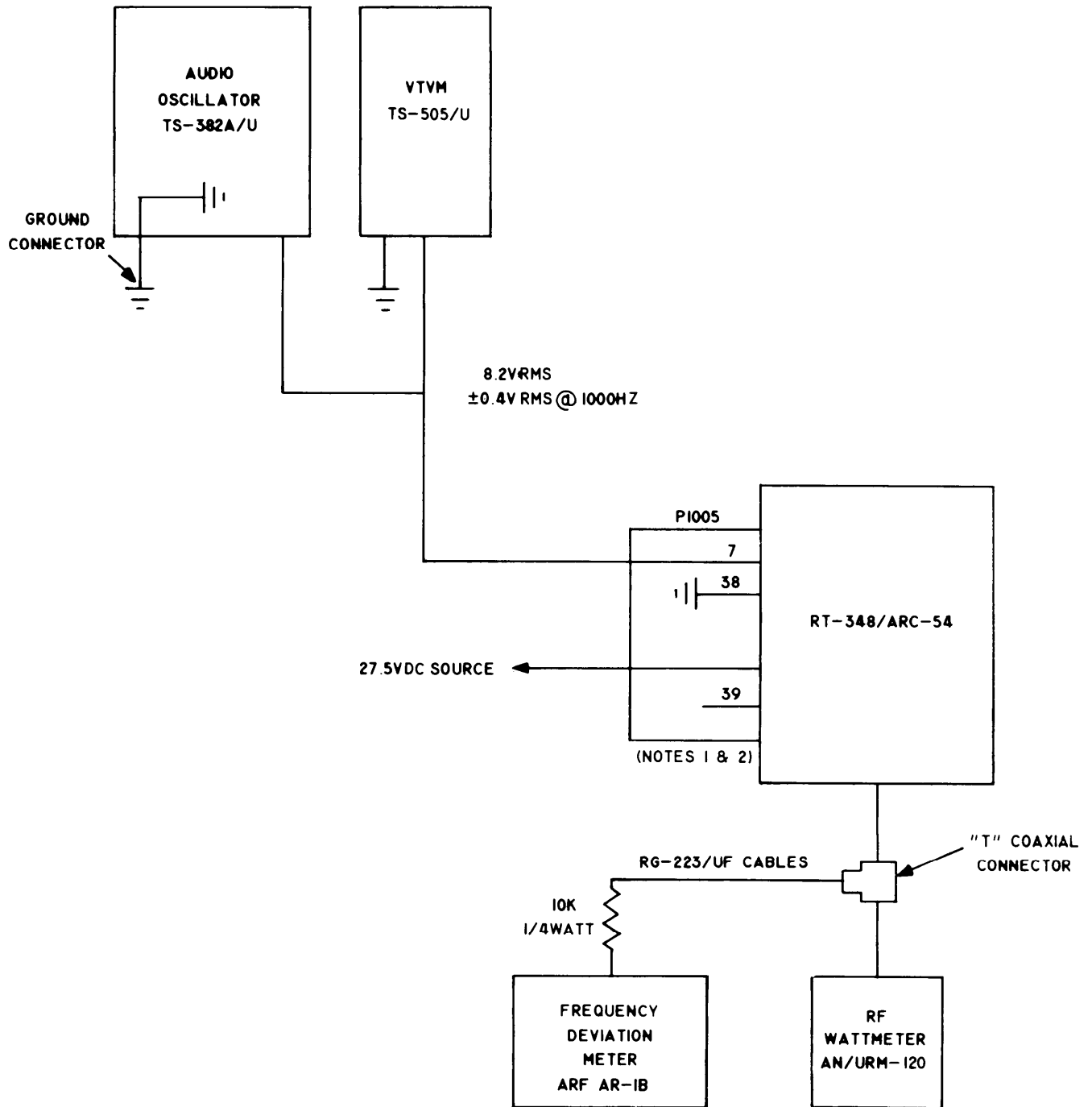

NOTES

1. PIN 39 MUST BE UNGROUNDED FOR TONE DEVIATION (150HZ).
2. GROUND PIN 39 FOR "X" MODE OPERATION.

EL740-5821-91-004-SB-2

Figure 2. Transmitter test setup XMODE.

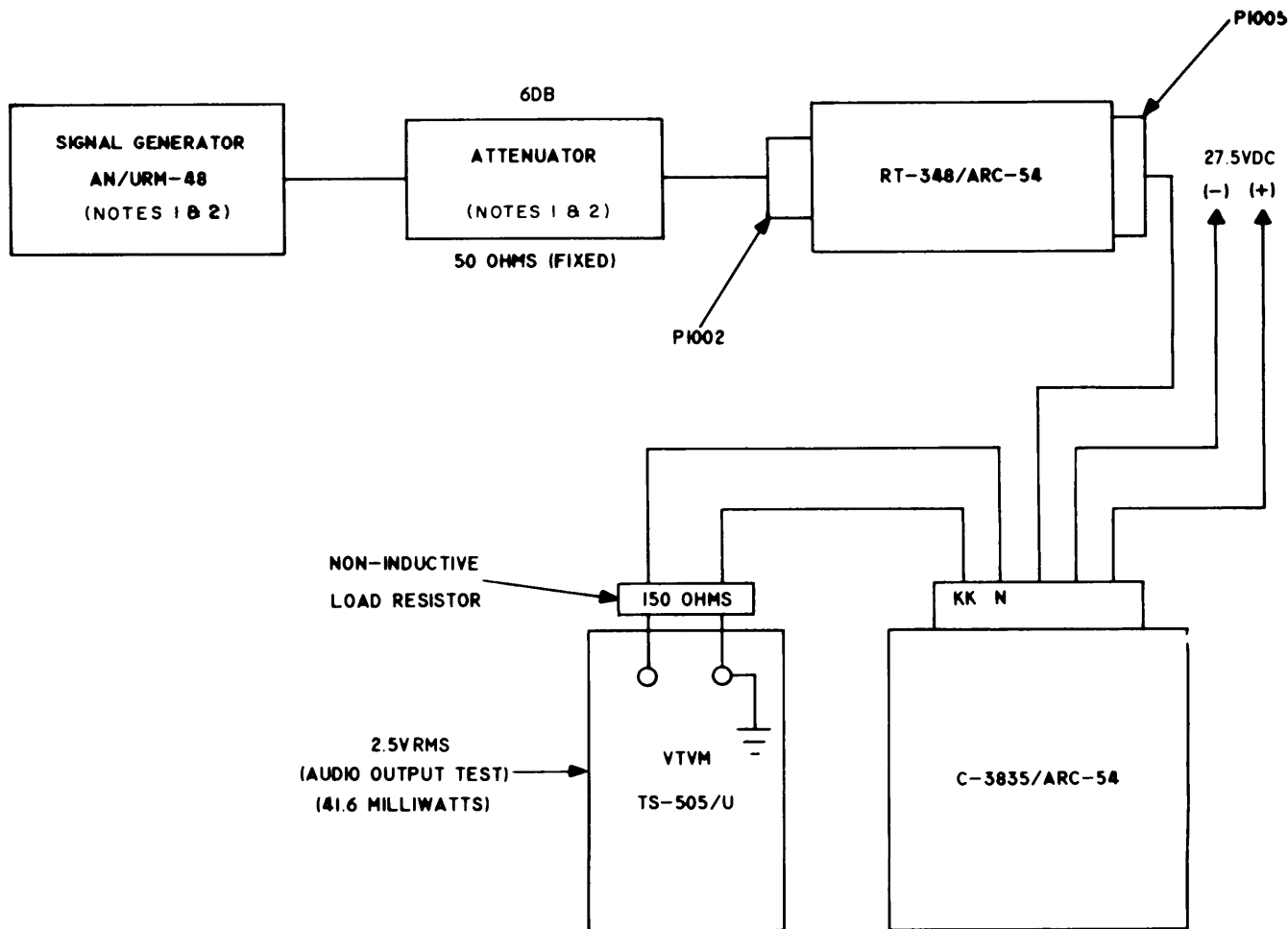

NOTES:

1. SET GENERATOR TO;
 - A. 1.5 MICROVOLTS, FOR SENSITIVITY TEST
 - B. 100 MICROVOLTS, FOR AUDIO OUTPUT TEST
 - C. AS INDICATED IN PARAGRAPH (5) (C) FOR SQUELCH SENSITIVITY TEST
2. DO NOT USE PADS OR TERMINATIONS FURNISHED WITH SIGNAL GENERATOR AN/URM-48 BECAUSE OF INHERENT IMPEDANCE MISMATCH. USE A 50 OHM 20DB PAD, WITH ANY OTHER GENERATOR USE A6DB PAD

EL740-5821-91-004-SB-3

Figure 3. Receiver sensitivity, squelch sensitivity and audio output test.

homer module for a reading of 37.5 microamps on the microamp meter, or until the signal strength indicator on the ID-1351 /A is centered on the first dot below the rest position of the pointer. This requirement shall also be met at one frequency in each of the following ranges: 30.00 MHz and 67.00 MHz to 69.95 MHz. Any readjustment of R-211 at other than 50 MHz should be rechecked at 50 MHz for a compromise reading.

e. Defect classification.

(1) Mechanical-visual.

(a) Critical. Refer to the definition of a critical defect.

(b) Major.

1. Damage due to handling or storage (crushed, deformed, or broken).
2. Soldering: defects as listed in MIL-STD-252A.
3. Solderless connectors: defects as listed in MIL-TD-252A.
4. Cabling and wiring: defects as listed in MIL-STD-252A.
5. Hardware: defects as listed in MIL-STD-252A.
6. Foreign objects: defects as listed in MILA3TD-252A.

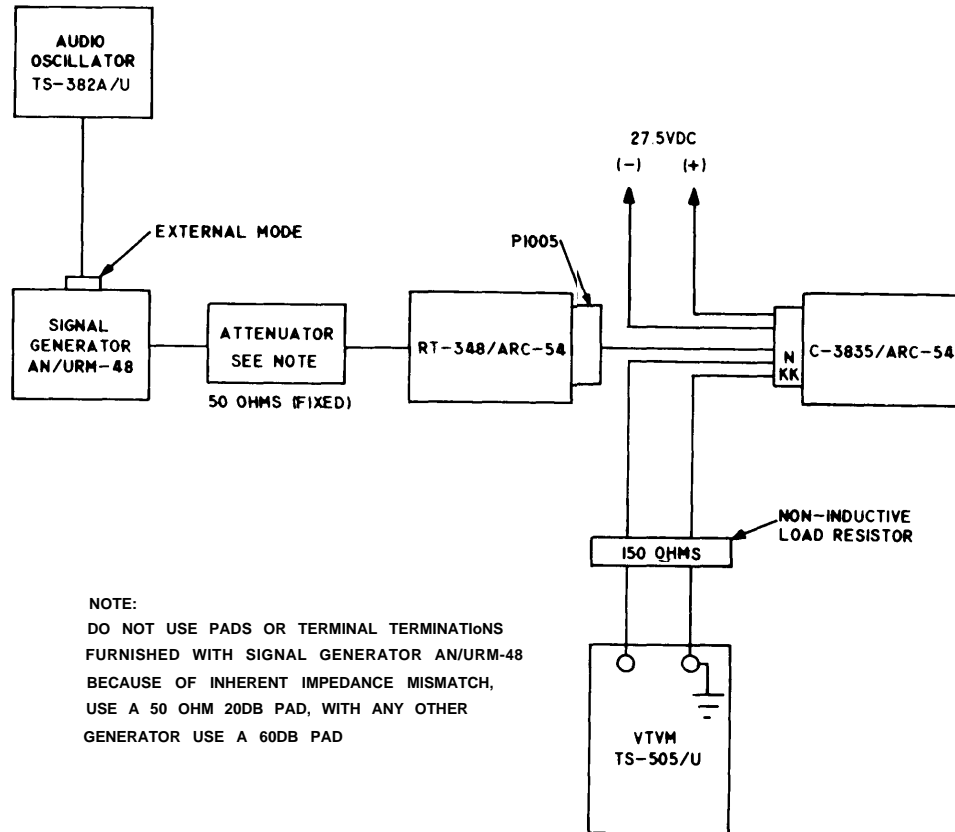

EL740-5821-91-004-SB-4

Figure 4. Tone squelch test.

7. Potential short circuits: defects as listed in MIL-STD-252A.

8. Finish: defects as listed in MIL-STD-252A.

9. Marking: defects as listed in MIL-STD-252A.

10. Parts: defects as listed in MIL-STD-252A.

11. Contacts: defects as listed in MIL-STD-252A.

12. Plating: painting or MFP missing.

13. Dimensional: a dimensional defect which directly affects interchangeability, assembly, or operation.

(c) *Minor.*

1. Soldering: defects as listed in MIL-STD-252A.

2. Solderless connectors: defects as listed in MIL-STD-252A.

3. Cabling and wiring: defects as listed in MIL-STD-252A.

4. Hardware: defects as listed in MIL-STD-252A.

5. Finish: defects as listed in MIL-STD-252A.

6. Marking: defects as listed in MIL-STD-252A.

7. Parts: defects as listed in MIL-STD-252A.

(2) *Electrical.*

(a) *Critical.* Refer to the definition of a critical defect.

(b) *Major.* Any electrical defect, other than critical that does not meet the requirements specified for each item shall be considered a major defect.

(c) *Minor.* None. All electrical defects shall be considered critical or major, as applicable.

(3) *Packaging and marking, major.*

(a) Use of improper or defective material.

(b) Quantity of unit package not as specified.

(c) Incorrect packaging method supplied.

(d) Cushioning or padding omitted.

(e) Cushioning or padding inadequate for

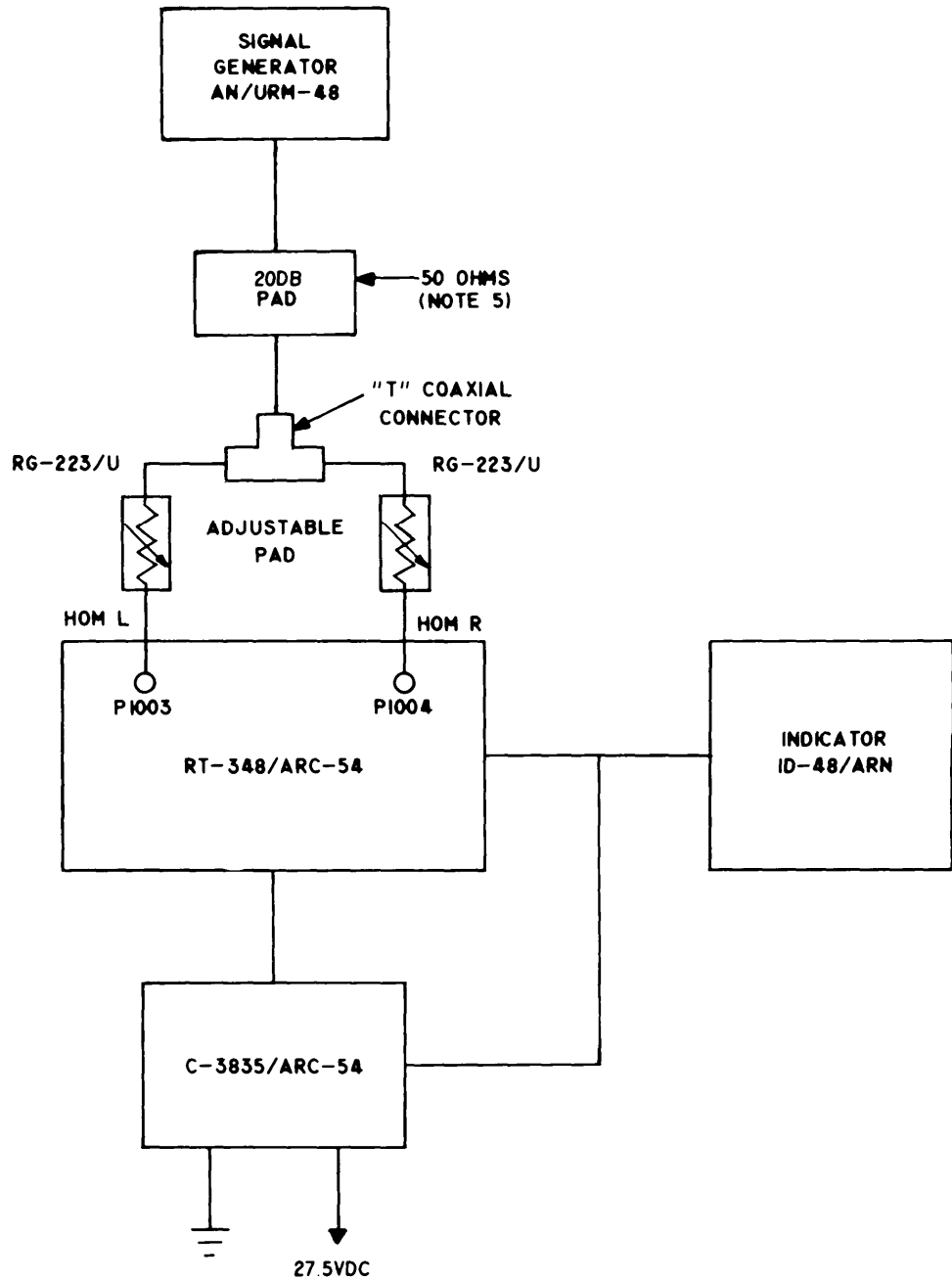

NOTES:

1. SIGNAL GENERATOR UNMODULATED.
2. ADJUSTABLE PADS SET FOR 6DB FOR CENTERLINE ADJUST AND SENSITIVITY MEASUREMENT.
3. MIN. SENSITIVITY 4.8UV FOR FLAG DOWN WITH PADSAT 6DB.
4. HOMING L AND HOMING R CABLES SHALL BE WITH IN 1/2 INCH OF BEING EQUAL IN LENGTH "T" CONNECTOR TO RT-348/ARC-54.
5. DO NOT USE PADS OR TERMINATIONS FURNISHED WITH SIGNAL GENERATOR AN/URM-48, WITH ANY OTHER GENERATOR USE A 60B PAD.

EL740-5821-91-004-SB-5

Figure 5. Homing test.

the protection of the barrier material from projections, sharp edges, or other similar features of the item.

(f) Cushioning inadequate for the physical and mechanical protection of the item.

(g) Unsealed, punctured, or improperly sealed barrier bag, wrap, or envelope.

(h) Stock number omitted, incorrect, or illegible.

(i) Nomenclature omitted, incorrect, or illegible.

(j) Marking of quantity of items in package omitted, incorrect, or illegible.

(k) Different stock-numbered items in the same unit package.

(4) *Packing and marking, minor.*

(a) Item not properly blocked or braced within the unit package to prevent movement.

(b) Packaging material damaged.

(c) Conforming or cushioning wraps are not snug fitting and contain voids.

(d) Air is not expelled from the barrier before sealing.

(e) Any item of marking information other than (3) (h), (i), and (j) above listed under major defects omitted, incorrect, or illegible.

(5) *Packing and marking, major.*

(a) Use of improper or defective material.

(b) Quantity in pack, not as specified.

(c) Gross weight in excess of specified amount.

(d) Box closure not as specified,

(e) Type, grade, class, and style of the shipping container not as specified.

(f) Strapping omitted (when required).

(g) Strapping inadequate or incorrectly applied (when required).

(h) Items not adequately blocked, braced, or cushioned within the shipping container to prevent movement or damage.

(i) Shipping documents or packing list omitted.

(j) Stock number omitted, incorrect, or illegible.

(k) Nomenclature omitted, incorrect, or illegible.

(l) Marking of quantities of item in pack omitted, incorrect, or illegible.

(m) Destination marking omitted, incorrect, or illegible.

(n) Special marking or labeling (when required) omitted, incorrect, or illegible.

(o) Overseas code marking (when required) omitted, incorrect, or illegible.

(6) *Packing and marking, minor.*

(a) Unsealed carton.

(b) Defective taping or sealing of carton.

(c) Any other box defect, which may be considered minor by definition of MIL-STD-105D.

(d) Any item of required marking information other than paragraph (5) (j) through (o) above listed under major defects omitted, incorrect, or illegible.

f. *Calibration of Measuring and Test Equipment.* All measuring and test equipment shall have been calibrated and certified within its prescribed period, in accordance with TB 750-236, before use. Certification shall be affixed in such a way as to preclude any altering or tampering.

g. *Storage Inspection Records.* Results of inspections and tests shall be recorded on data sheets and a copy attached to each unit.

7. Inspection Frequency. a. Controlled humidity warehouse: 60 months,

b. Heated warehouse: 36 months.

c. Unheated warehouse: 18 months.

8. Type of Storage. Controlled humidity warehouse or heated warehouse.

9. Other Instructions. a. *Rejected Lots.* Each rejected lot shall be tagged and reclassified into the proper condition code in accordance with AR 725-50. For other than new material, all defective units in a lot shall be repaired, or disposition requested in accordance with AMC and depot procedures.

b. *Repackaging of Samples Inspected.* Restore the packaging of the samples inspected and accepted to the level of the lot which the samples were drawn.

10. Special Requirements. If the subject items are allocated for Foreign Military Sales, Grant Aid, or Loan, the following additional requirements must be met:

a. *Policies and Special Conditions:*

<i>Publication</i>	<i>Title</i>
AR 795-17	General Policies and Principles for Furnishing Army Material on a Grant Aid Basis.
AR 795-204	General Policies and Principles for Furnishing Defense Articles and Services on a Sale or Loan Basis.
DD Form 1513	Offer and Acceptance.

NOTE

Special terms, conditions, and agreements with the customer country, and shown on the DD Form 1513, must be complied with as well as any special instructions from the responsible commodity command.

b. Basic Issue List Items (BILI). The BILI deck, normally furnished to the depots by USAECOM BILI Office, Lexington Blue Grass Army Depot,

Lexington, KY. office symbol AMSEL-MA-AM-IL shall be utilized.

c. Level A Package and Packing. Level A packaging and packing is mandatory for Foreign Military Sales and Grant Aid shipments.

d. Depot Documentation. Depot documentation of final acceptance shall be furnished by the ECOM quality check team prior to ECOM inspection.

By Order of the Secretary of the Army:

Official:

VERNE L. BOWERS,
*Major General, United States Army,
The Adjutant General.*

BRUCE PALMER, JR.,
*General, United States Army,
Acting Chief of Staff.*

Distribution:

To be distributed in accordance with DA Form 12-34 (qty rqr block No. 52), requirements for Storage, Serviceability, Standards, SB 740 Series.

